



JETSLIDE system

-OWNER'S MANUAL-

TABLE OF CONTENT

G2 JETSLIDE	P.3
AIR ASSIST SYSTEM V3 (RIGID TANK)	P.9
ALUMINUM STIFFENING BEAMS	P.13
“V” PLATE	P.14
SAFETY PLATES (1,2 AND 3 CUBES LENGHT) & LUG CONNECTOR “ JETSLIDE ”	P.15
PWC WINCH	P.16
WINCH JETSLIDE BOAT (MAX 3000PDS/1360KGS)	P.17

CONFIGURATIONS AND ANCHORING GUIDELINES FOR “PWC” JETSLIDE SYSTEMS

1-SUGGESTED CONFIGURATIONS: 1-3 BASIC CONFIGURATIONS	P.18
2-ANCHORING:	
2.1-PILINGS	P.19
2.2-ANCHORING STRUTS	P.19
2.3-WALL ANCHORAGES	P.19
2.4-DOCK LEG SUPPORT	P.20
2.5-ROPES AND CLEATS	P.20

CONFIGURATIONS AND ANCHORING GUIDELINES FOR “BOAT” JETSLIDE SYSTEMS

1-SUGGESTED CONFIGURATIONS: 1- THE CHART	P.21
2-ANCHORING:	
2.1-PILINGS	P.22
2.2-ANCHORING STRUTS	P.23
2.3-WALL ANCHORAGES	P.24
2.4-COMBINATIONS INCLUDING UNDER WATER ANCHORING POINTS	P.25

IMPORTANT NOTICE P.26

***** Note that it is preferable to consult the manual on a COLORED printed version, or directly on your computer screen*****

*The following instructions are guidelines to be followed. Candock will not be responsible for damages incurred by the non-compliance to these guide lines. All distributors are required and responsible to provide theoretical and practical training to clients on the complete use of the different dock systems. Candock inc. can not be held responsible in any way for any damages resulting from the fact that the client has not received adequate training.

IMPORTANT NOTICE

Here are some very important details concerning the installation of JetSlide systems for PWC and boats:

FOLLOWING INSTRUCTIONS ARE GUIDELINES TO BE FOLLOWED AND RESPECTED. CANDOCK IS NOT LIABLE FOR ANY DAMAGES WHATSOEVER, RESULTING OF THE NON COMPLIANCE OF THESE GUIDELINES.

All distributors are held responsible for giving training to their customers on the complete use of the system (theoretical and practical) with the watercraft of their customer. Candock Inc. will not be held responsible for any damages resulting from the fact that the operator did not receive the adequate training.

With the numerous varieties of boats on the market, it is possible that certain types will not be compatible with our system. Candock Inc. cannot be held responsible for this fact. It is impossible for us to be able to test all the existing types of boats in the world.

Never use the JETSLIDE without adding cubes on its outskirts. ALWAYS abide to the suggested number of cubes, for any system including a JETSLIDE. For example, if we specify that a system "x" requires a single row of cube on the outskirts of the JETSLIDE, this guidance must be followed to ensure optimal efficiency of the system. The only place where you can add "unnecessary" cubes is "in front" of the JETSLIDE and cubes that surround it.

G2 JETSLIDE

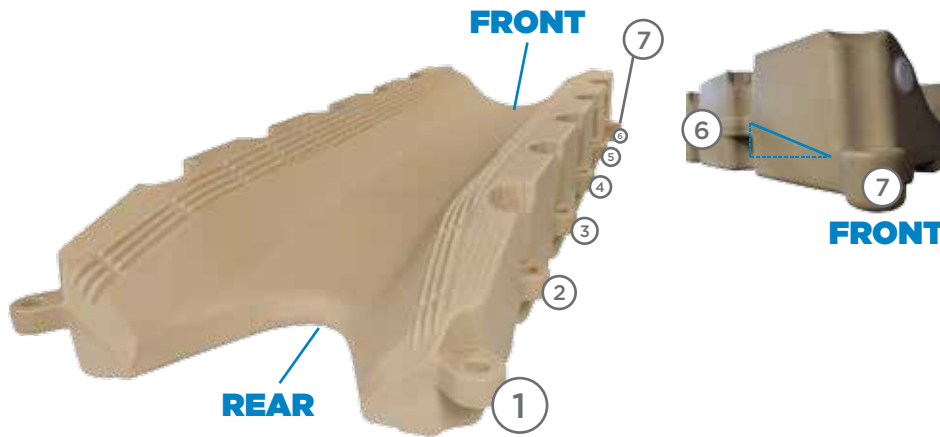

Available colors are GREY and BEIGE
 Other colors also available upon special request.

Material/Composition :

High-density polyethylene resin

Interior :

Expanded Styrofoam

Dimensions :

L x W : 288 cm (114") x 96 cm (38")
 H : 38 cm (15")

Weight :

68 kg (150lbs)

TERMINOLOGY

TABS: Prominent treated parts surrounding the the JETSLIDE. These tabs (#1 to #6), positioned at the lowest position available on our systems, act as the "female" part of the fastening system between the G2 CUBES, the G2 CONNECTING PINS, and the JETSLIDE. The #7 tab is, in turn, non-treated and is sitting underneath the 6 other tabs. This lower configuration is to allow the combination of 2 JETSLIDES one in front of the other. This lower tab simply act as a support for tab #1 of the second JETSLIDE.

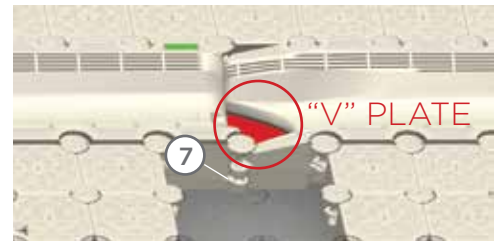

OVERVIEWS

MINIMAL CONFIGURATION

PWC JETSLIDE SYSTEM

<500LBS

- 1 x G2 JETSLIDE
- 14 x G2 CUBES
- 12 x G2 CONNECTING PINS
- 2 x CANDOCK SLIDING NUTS
- 14 x CANDOCK LUG CONNECTORS
- 14 x CANDOCK NUTS
- 29 x CANDOCK SPACERS

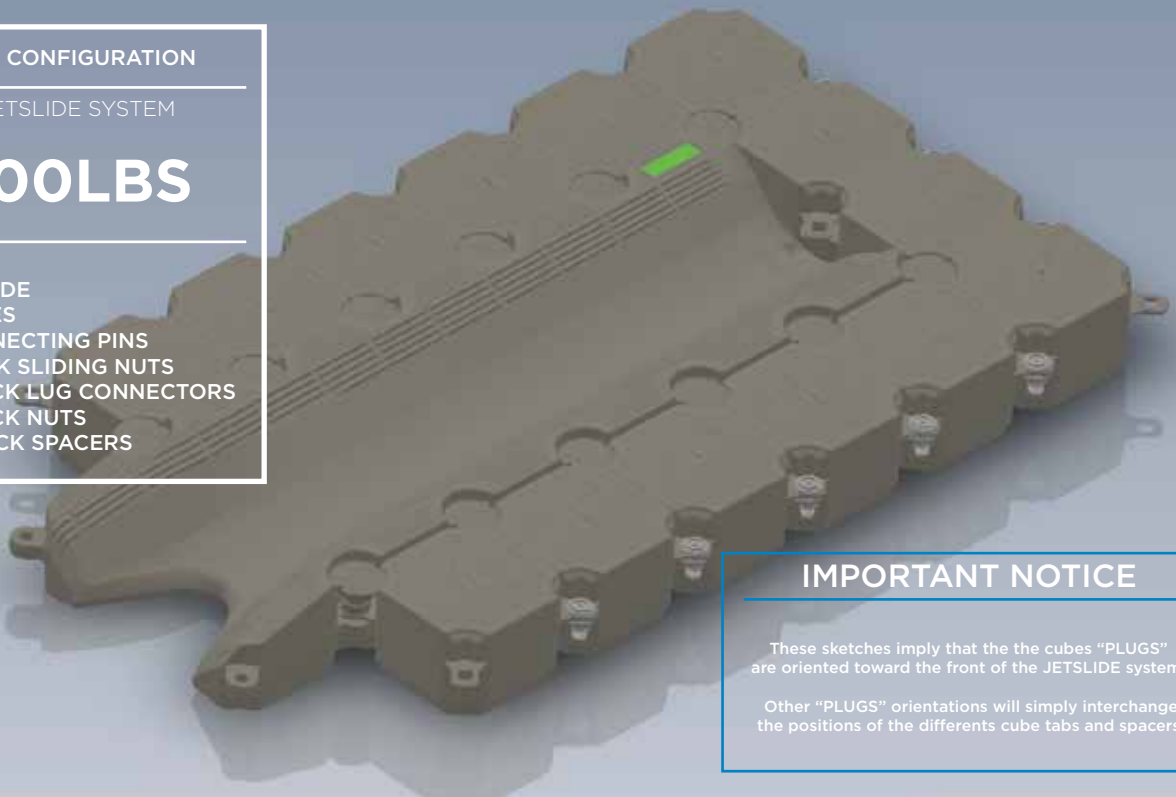

IMPORTANT NOTICE

These sketches imply that the the cubes "PLUGS" are oriented toward the front of the JETSLIDE system.

Other "PLUGS" orientations will simply interchange the positions of the differents cube tabs and spacers.

G2 JETSLIDE (SEQUENCE)

RIGHT SIDE ASSEMBLY

IMPORTANT NOTICE

These sketches imply that the the cubes "PLUGS" are oriented toward the front of the JETSLIDE system.

Other "PLUGS" orientations will simply interchange the positions of the differents cube tabs and spacers.

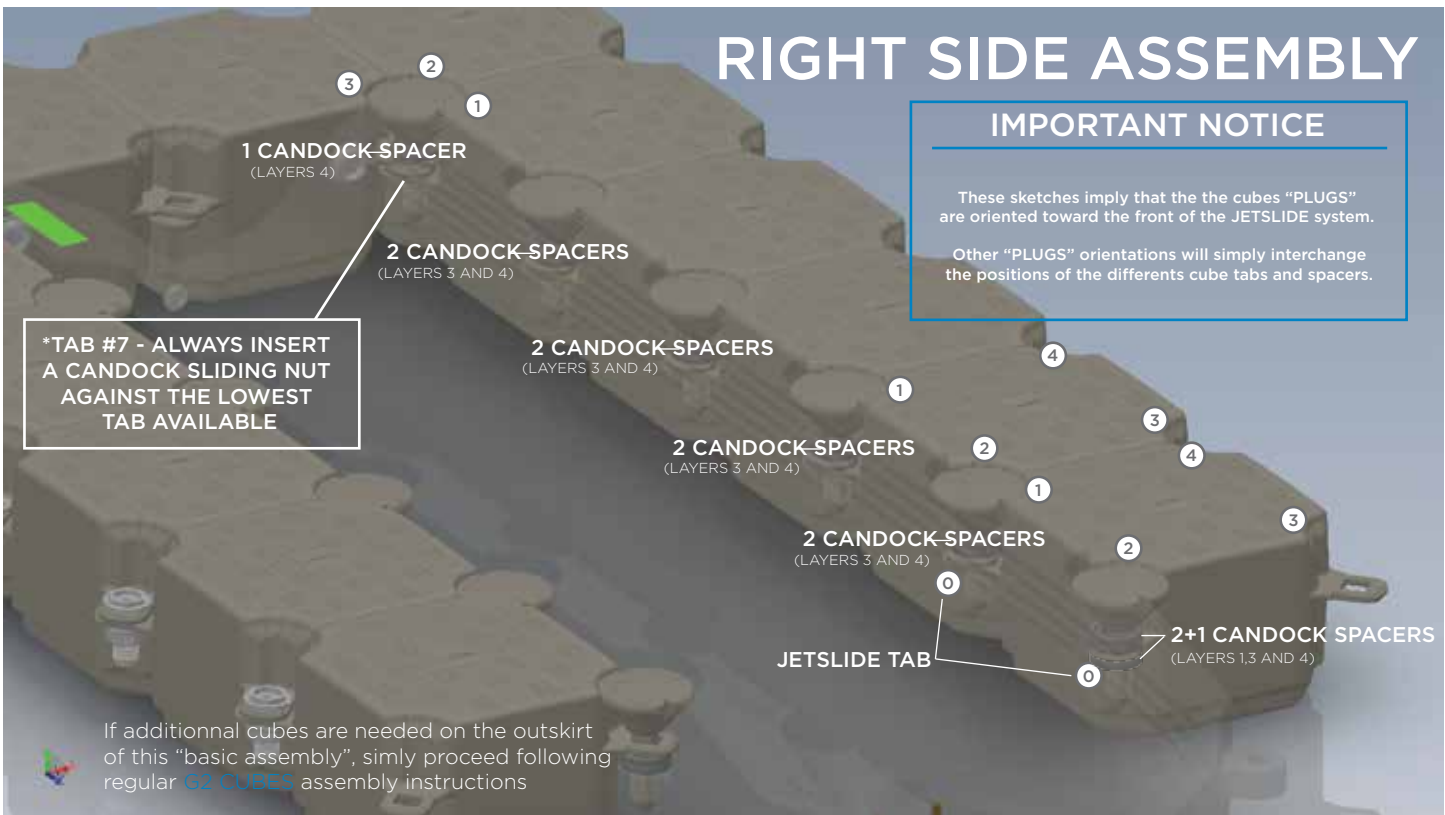

If additionnal cubes are needed on the outskirts of this "basic assembly", simly proceed following regular [G2 CUBES](#) assembly instructions

LEFT SIDE ASSEMBLY

*TAB #7 - ALWAYS INSERT A CANDOCK SLIDING NUT AGAINST THE LOWEST TAB AVAILABLE

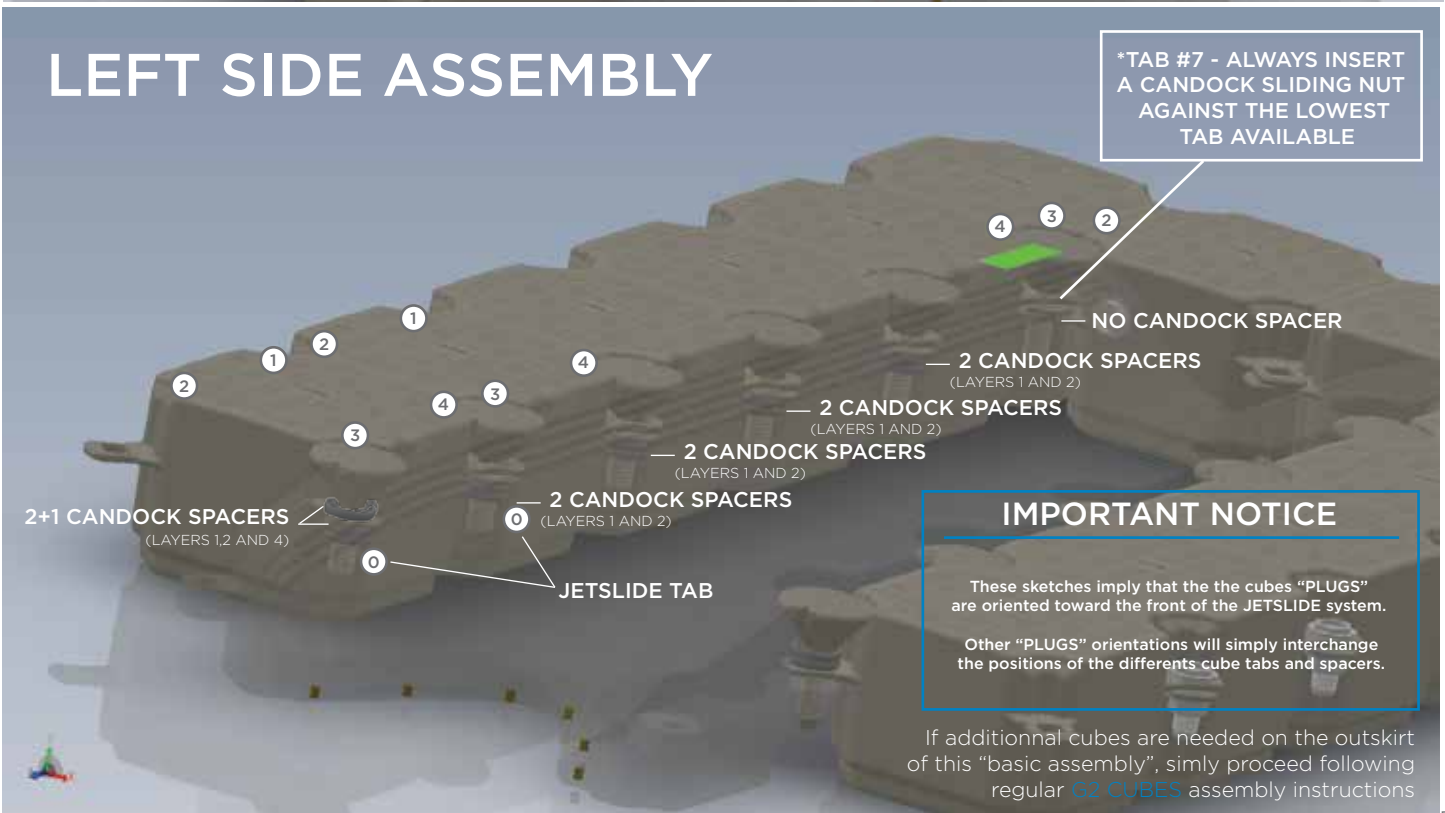

IMPORTANT NOTICE

These sketches imply that the the cubes "PLUGS" are oriented toward the front of the JETSLIDE system.

Other "PLUGS" orientations will simply interchange the positions of the differents cube tabs and spacers.

If additionnal cubes are needed on the outskirts of this "basic assembly", simly proceed following regular [G2 CUBES](#) assembly instructions

G2 JETSLIDE (SEQUENCE)

ASSEMBLY WITH "CLOSED" CORNER CUBE

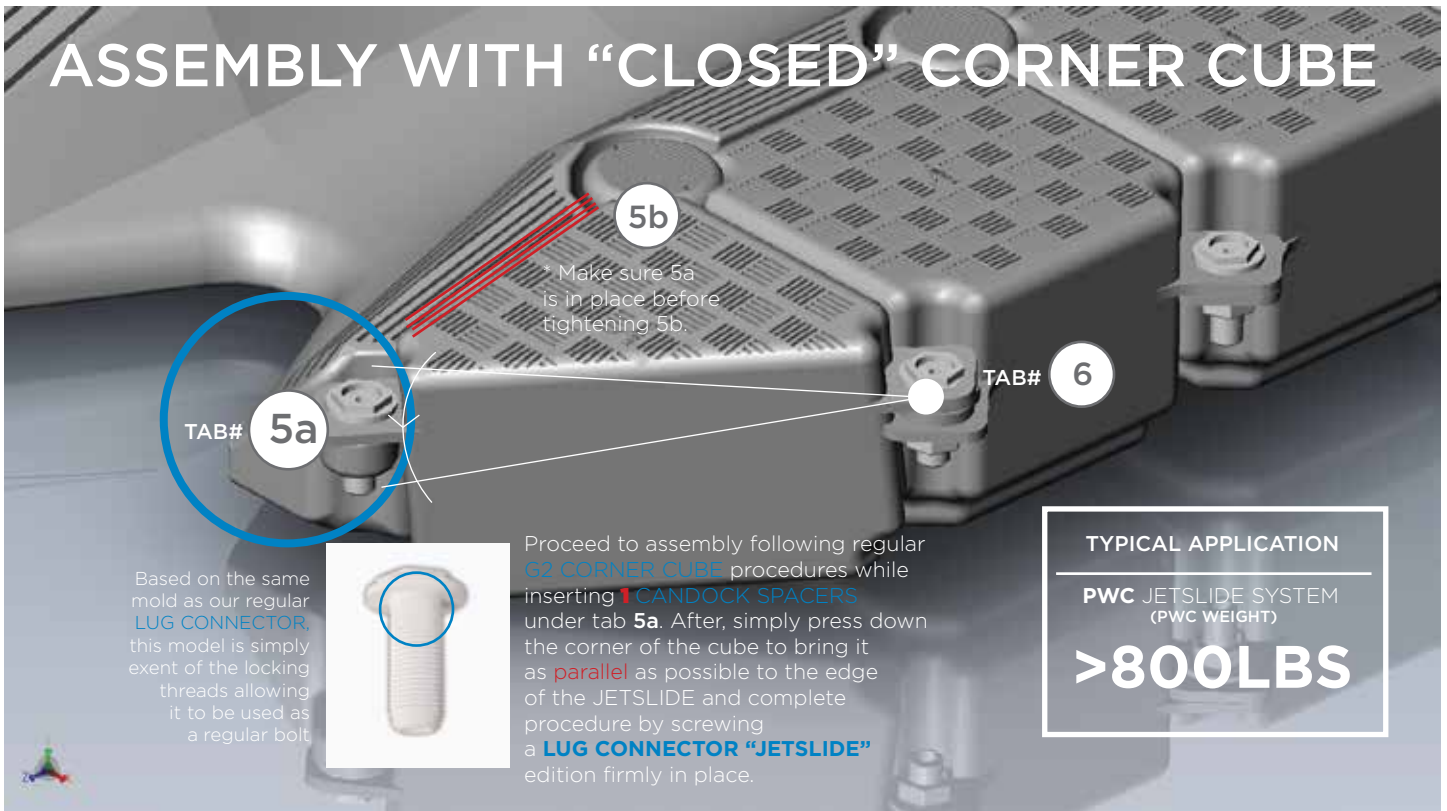

Based on the same mold as our regular LUG CONNECTOR, this model is simply an extension of the locking threads allowing it to be used as a regular bolt.



Proceed to assembly following regular G2 CORNER CUBE procedures while inserting a **CANDOCK SPACERS** under tab **5a**. After, simply press down the corner of the cube to bring it as **parallel** as possible to the edge of the JETSLIDE and complete procedure by screwing a **LUG CONNECTOR "JETSLIDE"** edition firmly in place.

TYPICAL APPLICATION
 PWC JETSLIDE SYSTEM
 (PWC WEIGHT)
>800LBS

ASSEMBLY WITH "OPEN" CORNER CUBE



Proceed to assembly following regular G2 CORNER CUBE assembly guidelines. Make sure to include any needed SPACERS as you go.

TYPICAL APPLICATION
 JETSLIDE SYSTEM
BOAT

G2 JETSLIDE (SEQUENCE)

ASSEMBLY

TIPS:

- Assemble on a flat surface rather than water. It will be easier that way.
- Assemble the cubes around the JetSlide. If you attach it to a dock, make sure the plugs are facing the SAME DIRECTION. If your JetSlide is an independent unit, black plugs must be oriented toward the front of your unit.

PROCEDURE:

1-Place **CANDOCK SPACERS** before inserting the connecting pins. When the cubes are put together, the tabs will nest on top of each other. The tabs are numbered from 1 to 4 for the regular **G2 CUBES** ("1" being the lowest and "4" the highest). The **JETSLIDE's** tabs (# "0") are placed just below the tab #1 of the cubes. You must insert spacers at the right positions to generate the equivalent of 4 tabs on top of the **JETSLIDE's** tabs.

2-Insert spacers as you position the **G2 CUBES** around **JETSLIDE**.

3-Insert **G2 CONNECTING PINS** and initiate the screwing process by hand. This will prevent pre-mature wear and tear..

4-When the pins are properly inserted, proceed by screwing manually and/or mechanically with our pre-destined tools. Either the **KEY FOR G2 PIN "COMBO PACK"** or the regular **G2 KEY FOR PINS**.

5-Make sure to securely tight the **G2 CONNECTING PINS** until snug, without over tightening them

4) In **POSITION ①** , the connecting pins require a **CANDOCK SLIDING NUTS**

because the **JETSLIDE** has no threaded tab at those corners. Place a **CANDOCK SLIDING NUT** on the lowest tab available.

5) Install the exterior **CANDOCK LUG CONNECTORS + NUTS** assembly around the **JETSLIDE** system and screw them using the proper tool.

Note: Usually, you should never have more than 2 tabs or more than 2 **CANDOCK SPACERS** to install.

IMPORTANT NOTICE

These sketches imply that the the cubes "PLUGS" are oriented toward the front of the **JETSLIDE** system.

Other "PLUGS" orientations will simply interchange the positions of the differents cube tabs and spacers.

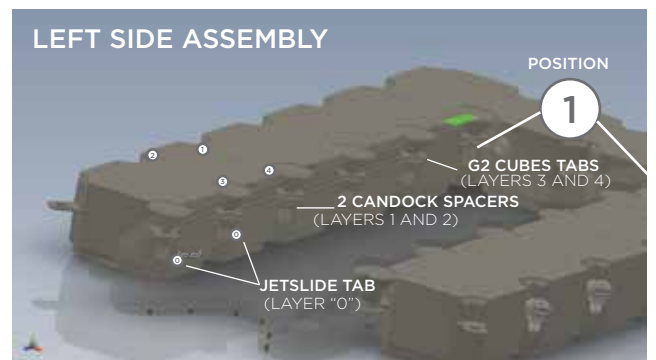
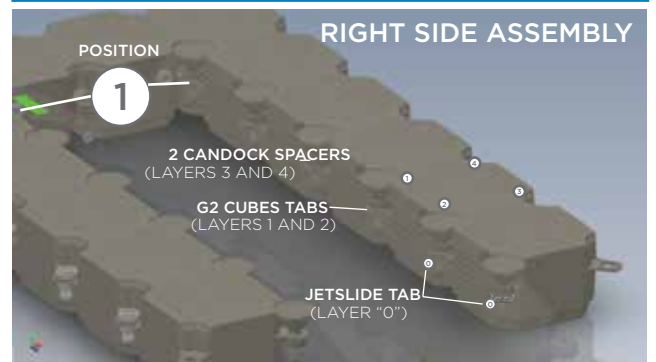

IF MULTIPLE JETSLIDE SYSTEM IS REQUIRED, PROCEED WITH THE SAME BASIC GUIDELINES WHILE INSURING THAT THE "LINKED" JETSLIDES ARE INITIALLY WELL ALIGNED TO INSURE EASY ASSEMBLY.

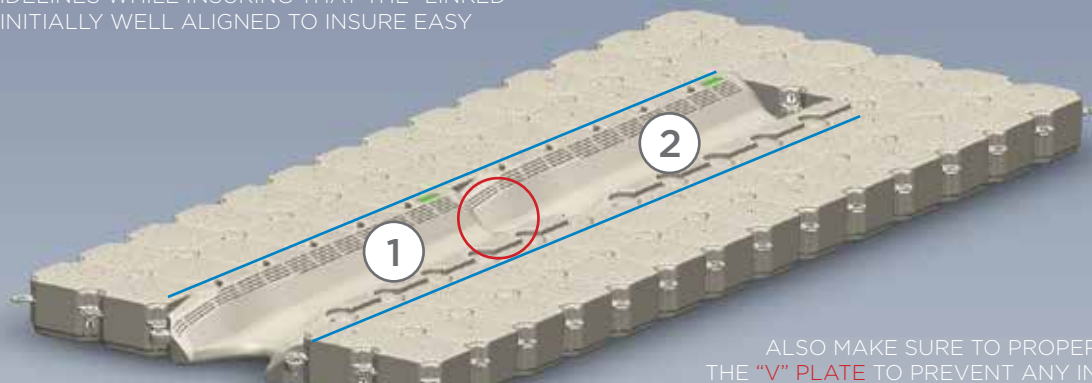

ALSO MAKE SURE TO PROPERLY INSTALL THE "V" PLATE TO PREVENT ANY IN ACCIDENT. THIS PLATE IS ONLY THERE TO PREVENT SOMEONE FROM FALLING IN THE HOLE THAT IS CREATED BETWEEN THE 2 JETSLIDES. (SEE INSTRUCTIONS ON PAGE 23)

G2 JETSLIDE (SEQUENCE)

OPERATING A WATER-CRAFT WITH THE JETSLIDE

GOING UP THE SYSTEM (BOAT AND/OR PWC)

PWC: Approach the JetSlide at idle, keeping the craft straight and centred with the JetSlide. When the bow of the craft will be in contact with the JetSlide, give small throttle strokes that will make the craft align with the JetSlide. When the craft is in line with the JetSlide, throttle in slowly. After a few tries, you will rapidly develop a feel of how much throttle you have to use to reach final position on the JetSlide

BOAT: engine must be trimmed down fully during the entering procedures and the depth of water at the back of the system must be 3' /1m minimum at all time to avoid damage to the boat. Increase throttle power until the boat is fully up on the system. When the engine gets in contact with the JetSlide, you will feel the craft stopping. You must immediately throttle down. This indicates that the craft is at final resting position. Entering the unit at high speed may damage the unit. We recommend, at first, that you try at slow speeds until you reach the correct speed. If the boat gets on the system but is not all the way in, you can continue throttling progressively until the boat reaches final resting position. Be careful, boarding at high speed can be dangerous.

NOTE: It is recommended to secure the craft to a cleat in order to prevent the craft from sliding back into the water accidentally. The craft can be locked to the JetSlide with a chain when you are not using it. Ask your dealer for details.

GOING DOWN THE SYSTEM

PWC:To go back into the water, take a standing position on your PWC and generate a backward movement by using your lower back and arms, pumping backwards rapidly until the PWC starts sliding back into the water. The procedure is easier when the PWC is wet. You can also stand up at the back of your PWC, grab the handle of the seat and transfer your weight back. The easiest way to return to water is to keep the front of the PWC in one hand and the handle of the other and then push gently. Be vigilant, because at some point, your PWC will start to go down by itself. At this point, you will have to get on it if you do not want your watercraft in the water without you.

BOAT: For a boat, put the engine in reverse and increase throttle until craft starts to go down by itself. It helps if you wet the system, especially if the boat was not used for a couple of days. It might be necessary to give a good throttle stroke to start the movement and then throttle down. For a Jet boat, the air assisted system will be required, no matter the weight of the boat.

WARNINGS & SPECIAL INSTRUCTIONS

1- Like all JetSlide installations, the system should not be installed in areas subject to waves of more than 0.75m / 2ft regularly. We recommend an installation in a protected area.

2-The installation of multiple PWC JetSlides side to side is possible, but a minimum of 2 rows of cubes is suggested between each JetSlide. An installation with only one row is possible, but there is a risk of damaging the machines and, therefore, the resulting damages will not be covered by the manufacturers warranty. Contact Candock for more information.

3-The handling of several JetSlides assembled in series by lifting (for winterizing by using a crane for example) is strictly forbidden. The excessive inflections will break the tabs of the JetSlide and the resulting damage will not be covered by the warranty. Contact Candock for more information.

4-The depth of water at the back of the system must be 1m / 3' minimum at all time to avoid damage to the boats.

5-Riveted hulls can damage the JetSlide. "Step hull" crafts are not suggested if used on a double JETSLIDE configuration.

6-Surface can be slippery when the system is wet.

7-The capacity of the JetSlide may change depending on the type of assembly, accessories and according to the weight distribution of the engines within the the watercraft.

G2 JETSLIDE (SEQUENCE)

WARNINGS & SPECIAL INSTRUCTIONS

8-Please note that some boats have cooling intakes for the engine which are located directly on the boats hull .These intakes need to be under the water line mark when the engine is running. **CANDOCK INC. WILL NOT TAKE ANY RESPONSABILITY FOR ANY TYPE OF DAMAGE TO A BOAT RESULTING FROM THIS. IT IS THE RESPONSABILITY OF THE DISTRIBUTOR TO MAKE SURE THAT THIS IS VERIFIED BEFORE SELLING THE INSTALLATION TO THE CLIENT.** We recommend that you inform your clients of that even if you are sure that the intake will be in the water.

9-The fact of removing cubes at the back of the system to lower the back of the system closer to the water could exert excessive pressure on the back tabs of the Jetslide and may cause damage which will not be covered by the warranty.

10-All distributors are held responsible for giving training to the customers on the complete use of the system, theoretical and practical with the watercraft of the customer. Candock Inc. will not be held responsible for any damages resulting from the fact that the operator did not receive the adequate training.

11-The boats and personnal water crafts must be completely mounted on the Jetslide at all time. A craft left on the Jetslide in a position where the major part of the weight is left on the back, could exert excessive pressure on the back tabs of the Jetslide and may cause damage which will not be covered by the warranty.

12-The installation of multiple BOAT Jetslides side to side is possible, but no rows of cubes should be removed with the aim of saving space. Moreover the totality of the back Jetslide must be left free to be able to go up and down. Therefore, it must not be connected to the adjacent systems.

13-It is normal that a certain wear of the JetSlide appears at the points of contact where the boat exerts more pressure.

14-All Jetslides produced after the November 1st, 2009 are now filled with foam making them unsinkable.

15-We make a point of specifying that any damages caused by the keel of motors or the propellers will not be covered by our warranty.

16-All systems destined for boats of more than 3000lbs/1360kgs (propeller or turbine powered) require the air assisted system
NOTE: In certain cases, a winch can be necessary to push the boat back in the water. This may void the necessity of the air assisted system. Any damage resulting from non-utilization of this winch will not be covered by the warranty.
(see specific instructions)

17-Stiffening beams may be required for your configuration, any damages resulting from non-utilization will not be covered by the warranty. (see specific instructions)*Only the bams provided by Candock inc. are approved.

18-With the numerous varieties of boats on the market, it is possible that certain types will not be compatible with our system. Candock Inc. cannot be held responsible for this fact. It is impossible for us to be able to test all the existing types of boats in the world.

AIR ASSIST SYSTEM V3 (RIGID TANK)

Available box colors is BLACK



MINIMUM WATER DEPTH FOR SAFE OPERATION:
4 FEET (1.3M)

Material/Composition :

Low-density polyethylene resin. (TANK)
 High Density polyethylene resin (BOX)

Dimensions :

Box: 14"x14"x35"
 35cm x 35cm x 89cm
 Tank: H26"xW42"xL117"

Included parts :

-1 Rigid Tank
 -1 Control box (Including other parts)
 -1 Air hose (28 feet / 8.3 meters)

Other mandatory products needed to install the AIR ASSIST (not included) :

-1 Deep cycle 12 volts marine grade battery.

Other products that may be needed to install the AIR ASSIST (not included) :

-SAFETY PLATES (1,2 or 3 cubes long)
 -"V" PLATE
 -Stiffening beam(s)
 -Air hose extensions

TERMINOLOGY

RIGID THANK AND FASTENING RODS



INCLUDED IN THE CONTROL BOX:

- Aluminum brackets for air hose(4)
 -Elbowed fittings (2)
 -Teflon tape roll (1)
 -Tank sealing plug (1)
 -SS 316 Threaded rod and hardware (4)
 -Fastening pin for Control Box (1)
 -Air pump (1)



ASSEMBLY PROCEDURE

RIGID TANK INSTALLATION PROCEDURE:

1-Start by connecting one of the white threaded elbowed hose to the tank.

*Mandatory Teflon tape is to be wrapped around the PVC threaded fitting prior screwing it in place.

**Make sure to screw the hose in the brass insert that will be towards the front of the system, on the appropriate side of the system, according to where the Control Box will be positioned (left or right).

***Manually tight the fitting until snug, without exaggerating. Make sure that the hose tip will point towards the front of the system when the tank will be in its final position.

**** The brass insert (2) that will not be used must be plugged using the white plug supplied. Install following the same instruction as for the elbowed hose.

2-Tie a lifeline to the tank and simply drag it in the water, in its upright position. The later will slowly fill itself with water while you continue with the rest of the procedure! Once filled, the tank's surface will float right above water so that it will easily be slipped underneath the dock later on.



AIR ASSIST SYSTEM V3 (RIGID TANK)

3-While the tank is sinking, simply determine the location of the Control Box. Make sure to position it in front of the system, on the same side as the elbowed fitting you've earlier connected to the tank.

**Keep in mind that the overall length of the air hose in 28' (8.5m).*

4-Remove the regular connecting pin that is at the center of the designated location of the Control Box and replace it with the mounting connecting pin that is found inside the Control Box.

5-Finalize the positioning of the Control Box by inserting it on through the threaded rod of the mounting connecting pin. Secure it by screwing the nut and washer kit.

**Make sure that air exhaust of the Control Box are located on the correct side of your system, in accordance with the air hose side and the elbowed fitting that is connected to the tank.*

6- Take the second threaded elbowed hose and connect it to the Control Box, on the highest exhaust available.

**Mandatory Teflon tape is to be wrapped around the PVC threaded fitting prior screwing it in place.*

***Make sure to screw the fitting in a way that will be oriented towards the rear of the system, on the appropriate side of the system, according to the fitting that is already connected to the tank that is still in the water (left or right).*

****Manually tight the fitting until snug, without exaggerating. Make sure that the hose tip will point towards the back of the system and in a 45 degree angles towards the water.*

7-Connect the longest air hose to the Control Box fitting that you've just connected to the Control Box.

**Manually tight the fitting until snug, without exaggerating.*

***Ideally, keep the whole hose on the dock while proceeding.*

8-While using the rope, or simply by going for a swim, gently slide the tank underneath the system so that it's as close as possible to its final position (see picture).

9-Once the tank is in position, use the designated threaded steel rods to secure the tank underneath the system. Remove the loose nut and washer kit from one of the threaded rod and insert it, from underneath the designated tab of the tank, and pass it through the white lug connector that is just above the tab of the tank and secure by screwing the nut and washer assembly back on top Repeat for the remaining rod kits (3). For this step, only tight the nuts so that you'll still be able to fine-tune the position of the tank. After the tank has been perfectly aligned, complete the procedure by firmly screwing the nut and washer assembly on the threaded rod, without exaggerating.

**Make sure to apply "anti-seize" grease to the threaded rods and nuts to insure that they will be easy to dismantle, if needed in the future.*



AIR ASSIST SYSTEM V3 (RIGID TANK)

10-You may now connect the long air hose to the elbow fitting that is fixed on the air tank.

**Manually tight the fitting until snug, without exaggerating.*



11-You can now proceed to securing the air hose along the side of the system using the provided aluminum brackets and regular "tie raps". Simply remove the lug connector, insert the aluminum bracket and reinstall the later prior to fixing the hose with the "tie raps".



BATTERY INSTALLATION

The system is designed to be powered by a 12 V battery (not included). Just put the battery in the Control Box and connect to the pump using the alligator clips of the pump.

**We strongly suggest to pair your battery to a charge keeper of a solar panel to insure sufficient power to your battery, at all time. Simply ask your Candock distributor if you should need additional information on the subject.*



4-OPERATIONNAL INSTRUCTIONS (INFLATING/DEFLATING PROCEDURE)

*****For adequate instructions in regards with driving up and down of the system, please refer to the OPERATING INSTRUCTIONS of this manual.**

1-Position the valve system to its "INFLATE" configuration (keep the upper valve in an "opened" position and the lower valve in a "closed" position). SEE PICTURE

2-Activate the pump for a brief moment just to make sure it properly works. If it does work, proceed. If the pump does not work, double check its connections and/or contact your closest Candock distributor for assistance.

3-Activate the pump for approximately 30 seconds, then, place the valve system to its "CLOSED" configuration (quickly close the upper valve of the Control Box) and switch the pump off.

4-Now, in order to insure a completely air and water tight circuit (Air hose, fittings (2) and Control Box), use soapy water and make sure the whole system doesn't leak in any ways. Check the fittings, joints and any other potentially breached component. For components below the water line, check for bubbles

5-To complete the berthing procedure, re-position the valve system to its "INFLATE" configuration, reactivate the pump and carry on with the inflation of the tank for 5 to 6 minutes or until the watercraft is at a desired height from the water line (the vessel and its engine should be completely out of the water). If the inflation procedure is stretched to an excess of 6 minutes, you should see "air bubbles" coming out the rigid tank, this will indicate that you've reached the maximal lifting capacity of the system. You may now position the valve system to its "CLOSED" configuration (close the upper valve of the Control box) and deactivate the electric pump.

6-Finally, to initiate the launching procedure, simply position the valve system to its "DEFLATE" configuration (open the lower valve of the Control box while keeping the upper valve closed*) until air is completely out of the tank (this should take about 5 to 6 minutes).

**This will prevent water from going into the pump thus preventing pump malfunction*



AIR ASSIST SYSTEM V3 (RIGID TANK)

NOTICE

Once your boat is on the JetSlide (See instruction for use of Candock JetSlides), stop the engine and go on the dock. For security reasons, it is always better to secure the boat to your Candock dock using a rope.

***Caution: DO NOT RUN THE PUMP FOR MORE THAN 10 MINUTES, IT MAY DAMAGE THE PUMP. IF AFTER 10 MIN, THE TANK IS NOT FILLED WITH AIR OR IF THE BOAT IS NOT COMPLETELY OUT OF WATER, PLEASE CONTACT YOUR CANDOCK DISTRIBUTOR. IN THE SAME VEIN, IT IS IMPORTANT TO KEEP THE VESSEL LEVELED. INDEED, OVER-LIFTING THE REAR OF THE SYSTEM MAY CREATE ISSUES AS RAIN WATER MAY EXCESSIVELY ACCUMULATE IN THE FRONT OF THE BOAT WHEN NOT IN USE.**

MAINTENANCE

- During winter, or if you do not use the pump for a long time, simply disconnect the battery and store both items in a dry place.
- Inspect the Air ASSIST system components once a year with soap and water to prevent leaks and inspect to see if there is any premature damage.
- Remove the tank and beams for winter if ice is forming during winter.

ALUMINUM STIFFENING BEAMS

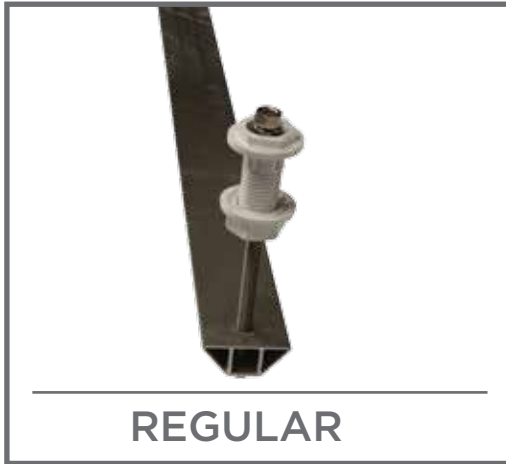

Material/Composition :

Aluminum and stainless steel

Dimensions :

L : 117" or 155"

Needed tools :

15/16" key wrench

Key for nut

or

Ratchet key for nut + ratchet tool

Needed accessories

(sold separately) :

2 CANDOCK LUG CONNECTOR

2 CANDOCK NUT

OVERVIEWS

To stiffen your JetSlide system and minimize the lifting of the cubes around the system, a stiffening beam system was designed. The positioning of the beams is not optional. These should always be used when recommended and the use of bars other than those provided by Candock is prohibited unless written permission from Candock. The first bar is always installed between the 1st and 2nd row of cubes in the back. The 2nd bar is installed between the 3rd and 4th row of cubes. In order to prevent the lifting of the cubes on the sides, more bars could be required, install them where needed.

THE RULE OF THUMB: 1 BEAM EVERY 1000LBS

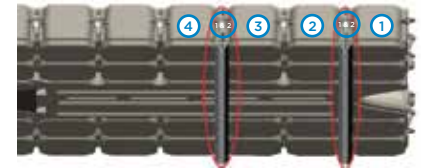

ASSEMBLY PROCEDURE (2 INSTALLERS ARE SUGGESTED FOR THIS PROCEDURE)

1-Initiate the process by installing the [CANDOCK LUG CONNECTORS](#) and [CANDOCK NUTS](#) to every tabs you will later install the beams left and right sides). Secure the latter following the procedure found in the [BASIC PRODUCTS OWNER'S MANUAL](#)

3-Holding the very end of the threaded rods, simply slide the BEAM underneath the system starting from the rear. Make sure to install the beams that will be at the front of the system and make your way to the back with the subsequent beams.

4-Once aligned, secure the beam to the [CANDOCK LUG CONNECTORS](#) with the hardware kit supplied with the bars. Pass the threaded rod through [CANDOCK LUG CONNECTORS](#) and then place the washer, lock washer and nut.

5-Complete installation by adjusting the beam position for it to be perfectly horizontal and in a way that it will create a straight and flat surface from side to side. The over-tightening of the stabilizer bars may exert undue pressure on the tabs and cause damages to the JetSlide that are not covered by warranties



“V” PLATE

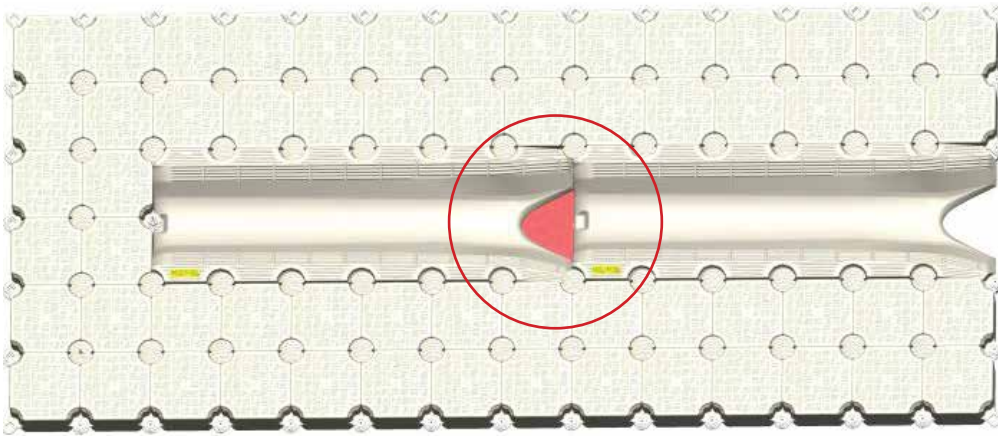

Material/Composition :
 HDPE

Needed tools :
 Halen key



OVERVIEWS

You'll notice that the installation of in line JetSlides leaves a gap (in red on the attached image) at the V of JetSlide. To fill the gap you must install a V-plate which can be simply screwed under the JetSlide. It is very important for the safety of users. Candock Inc. disclaims all liability for accidents if the V plate is not installed. **BEWARE, THIS PLATE MUST NOT BE INSTALLED ON THE FIRST JETSLIDE.**

ASSEMBLY PROCEDURE

1-Simply secure the plate against the JETSLIDE using the supplied hardware. (6)

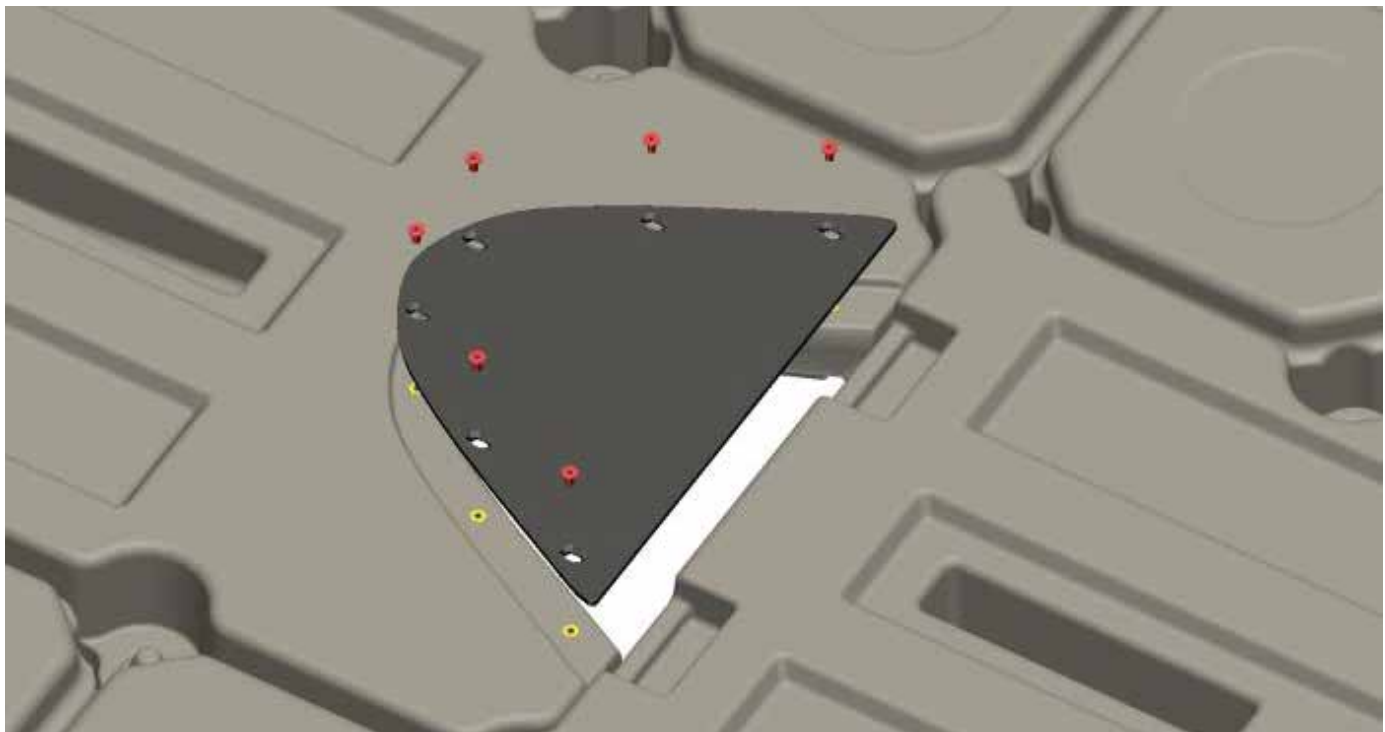

SAFETY PLATE (1,2 AND 3 CUBES)



Material/Composition :
 HDPE

Needed tools :
 15/16" key wrench
 Key for nut
 or
 Ratchet key for nut + ratchet tool

Needed accessories (sold separately) :
 5 TO 9 CANDOCK LUG CONNECTOR **JETSLIDE**
 5 TO 9 CANDOCK SLIDING NUTS
 4 TO 8 CANDOCK SPACERS
 Depending on plate size.

OVERVIEWS

These Safety Plates, available in 3 different sizes, have been created to accommodate intermediary boat length. Indeed, instead of forcing our customers to buy a second **JETSLIDE** to accommodate their boat's length, we came up with this efficient yet very affordable solution to create enough room for their boat hull without sacrificing the efficiency of our systems.

*In use, the plate can deform slightly and keep this deformation. This deformation is expected and normal.
 **Please note that the surface of the safety plate can be slippery.

ASSEMBLY PROCEDURE

- 1 - Place sliding nut on cube tabs.
- 2 - Place spacers on cube tabs to equalize the height with the highest cube tab.
- 3 - Put the safety plate without moving the spacers.
- 4 - Screw **CANDOCK LUG CONNECTORS JETSLIDE*** on the fixation tab of the safety plate.

Based on the same mold as our regular **LUG CONNECTOR**, this model is simply exempt of the locking treads allowing it to be used as a regular bolt



PRODUCT QUANTITIES ACCORDING TO PLATE SIZE*:

PART NUMBER	DESCRIPTION	SAFETY PLATE 1 CUBE	SAFETY PLATE 2 CUBES	SAFETY PLATE 3 CUBES
CD075	SAFETY PLATE 1 CUBE	1	N/A	N/A
CD076	SAFETY PLATE 2 CUBES	N/A	1	N/A
CD077	SAFETY PLATE 3 CUBES	N/A	N/A	1
LK 703016	CANDOCK SPACER	4	6	8
LK 703013	CANDOCK SLIDING NUT	5	7	9
LK 703015	LUG CONNECTOR JETSLIDE	5	7	9

***According to an independent installation with plugs forward.**

PWC WINCH



Material/Composition :

Zinc plated steel
 Aluminum

Needed tools :

9/16" key wrench
 Key for nut
 or
 Ratchet key for nut + ratchet tool

Accessories included with the winch

1 CANDOCK LUG CONNECTOR
 1 CANDOCK NUT
 1 Aluminum mounting bracket
 1 Pulling winch (400 lbs capacity)
 equipped with a 15 ' strap and 1 hook.

OVERVIEWS

Winch to be used mainly with the Jetslide system to help launch your PWC. It can be installed in front to pull it or on the sides for launch manoeuvres.

ASSEMBLY PROCEDURE

- 1 - Depending on position of the assembly, adjust the angle of the winch on the plate using appropriate holes.
- 2 - Install [CANDOCK LUG CONNECTOR](#) / MOUNTING BRACKET ASSEMBLY where the winch is needed.
- 3 - Complete by by securely fastening the [CANDOCK NUT](#) against the [CANDOCK LUG CONNECTOR](#) as describd in the [BASIC PRODUCTS OWNER'S MANUAL](#)

*When positionned on the side of the assembly for back-up procedures, position the strap in a straight line with the front of the PWC.
 (as pictured on the image)

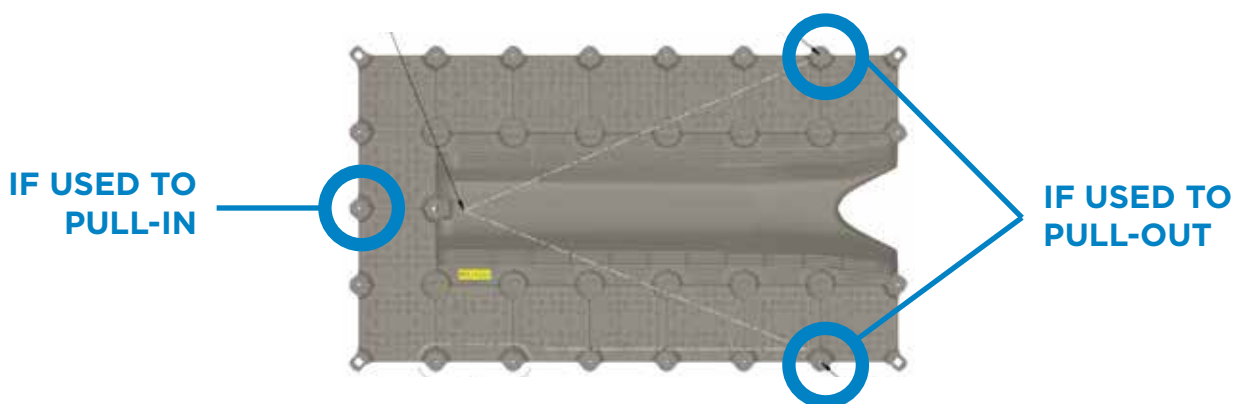

WINCH JETSLIDE BOAT (MAX 3000PDS/1360KGS)



Material/Composition :

SEACOAT™ corrosion protected steel
 Aluminum

Needed tools :

Key for nut
 or
 Ratchet key for nut + ratchet tool

Accessories included with the winch

1 Aluminum mounting bracket
 1 Pulling winch (1600 lbs capacity) equipped with a 20 ' strap and 1 hook
 1 20' long rope spliced at both ends.
 1 Pulley
 1 fastening carabiner
 1 Shackle

Other needed accessories

(sold separately)

4 CANDOCK LUG CONNECTOR
 4 CANDOCK NUT
 1 ANCHORING RING

OVERVIEWS

Sometimes, for a boat less than 1360kg / 3000lbs, a winch may be required to put the boat afloat.

NOTE: **Turn the handle of the winch until the boat is enough in the water that it can back off on its own power. Do not back the boat too much; it could slide in the water by itself.

ASSEMBLY PROCEDURE

1 - Install the ALUMINUM MOUNTING BRACKET where the winch is needed.

2 - Complete by securely fastening the CANDOCK LUG CONNECTOR and CANDOCK NUT against the cube tabs as described in the BASIC PRODUCTS OWNER'S MANUAL

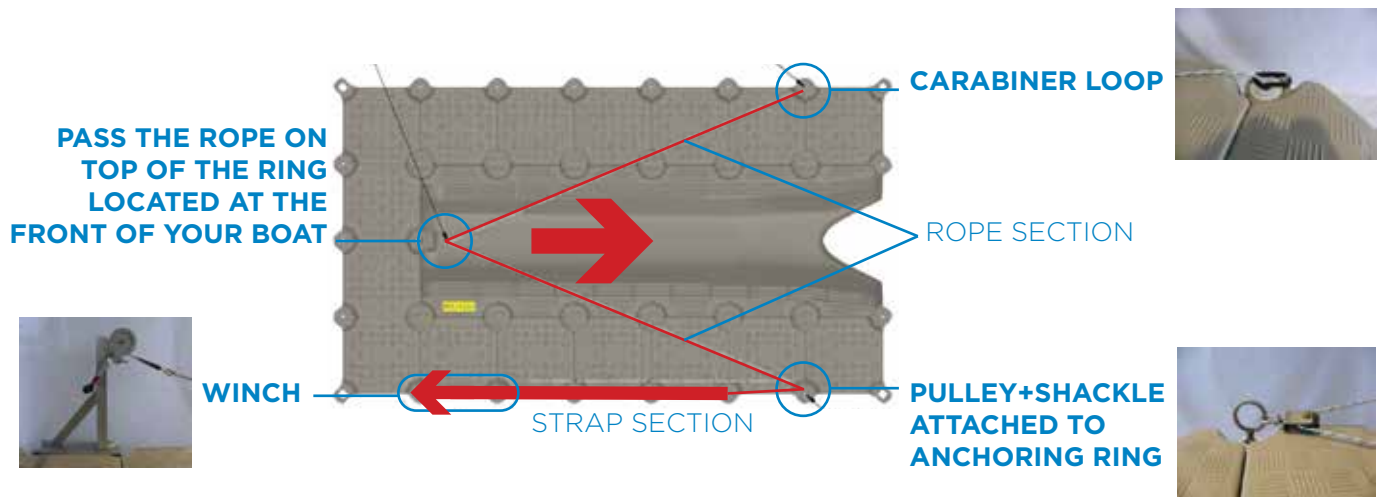

CONFIGURATIONS AND ANCHORING GUIDELINES FOR “PWC” JETSLIDE SYSTEMS

1- THE 3 REGULAR CONFIGURATIONS

These are the 3 typical configurations for PWC / JETSLIDE assembly. Note that they can be paired-up without any complication. The following guidelines are mandatory for optimal ease of use and for warranty coverage policies.

UNDER 500lbs

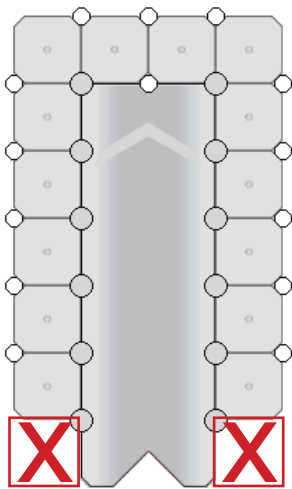

1

OVER 500lbs

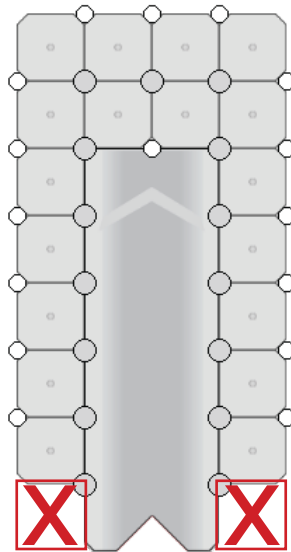

2

WITH CORNER CUBES

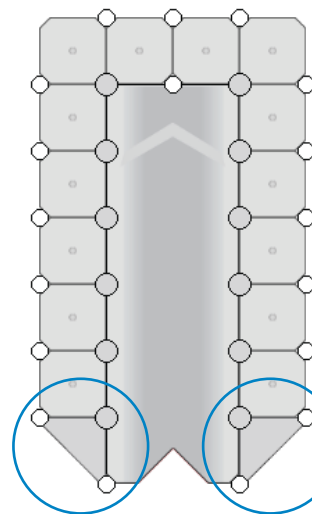

SEE PROPER ASSEMBLY
 TECHNIQUE AT **PAGE. 5**

3

NOTES:

- Always keep the system symmetrical **left/right**.
- In doubt, please refer to your Candock representative.
- These guidelines are imperative to insure full warranty coverage**
- Although we advocate 2 rows of cubes in between each **JETSLIDE**, a multiple **JETSLIDE** assembly can be configured with either 1 OR 2 rows of cubes between each **JETSLIDE**. **Be aware of possible injuries if only 1 row is to be considered. Space in between the Jetskis will be limited.**
- Adding the 2 corner cubes at the back of the system OR 4 extra cubes in the front of the assembly is suggested for larger PWC or if extra space is needed at the front of the system.
- Under absolutely no circumstances regular G2 CUBES are allowed to be placed at the rear corners of our systems.**

MULTIPLE JETSLIDES ASSEMBLY

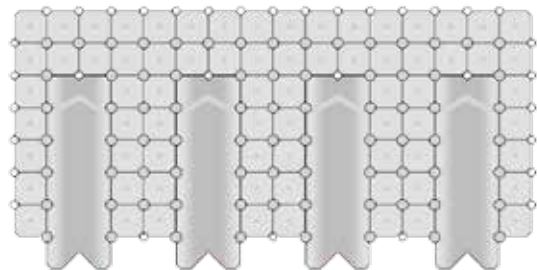

CONFIGURATIONS AND ANCHORING GUIDELINES FOR “PWC” JETSLIDE SYSTEMS

2-THE 5 ANCHORING OPTIONS

2.1 - PILINGS

IDEAL ASSEMBLY

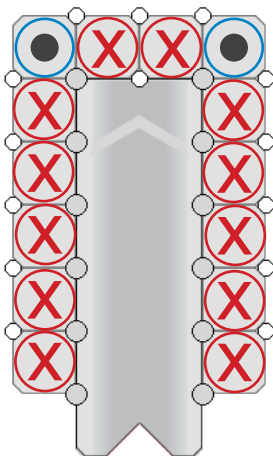

NOTES:

- Minimum of **2 PILES**
- Max. water depth is 2m / 6'.
- Always keep the anchoring symmetrical **left/right**.
- These guidelines are imperative to insure full warranty coverage
- In doubt, please refer to your Candock representative.

2.2 - ANCHORING STRUTS

IDEAL ASSEMBLY

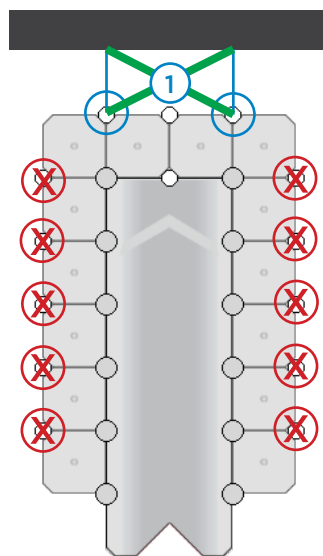

NOTES:

- Minimum of **2 STRUTS**
- Always keep the anchoring symmetrical **left/right**.
- Make sure to include steel cable in **“X”** position between struts.
- These guidelines are imperative to insure full warranty coverage
- In doubt, please refer to your Candock representative.

2.3 - WALL ANCHORAGE

IDEAL ASSEMBLY

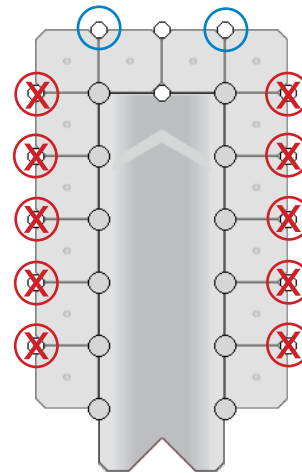

NOTES:

- Minimum of **2 WALL ANCHORAGE**
- Always keep the anchoring symmetrical **left/right**.
- THESE BRACKETS ARE STRICTLY FORBIDDEN IF NOT FIXED TO A FLOATING STRUCTURE AS THEY DO NOT ALLOW WATER LEVEL FLUCTUATION
- These guidelines are imperative to insure full warranty coverage
- In doubt, please refer to your Candock representative.

CONFIGURATIONS AND ANCHORING GUIDELINES FOR “PWC” JETSLIDE SYSTEMS

2-THE 5 ANCHORING OPTIONS (SEQUENCE)

2.4 - DOCK LEG SUPPORT

2.2 - ROPES AND CLEATS

IDEAL ASSEMBLY

IDEAL ASSEMBLY

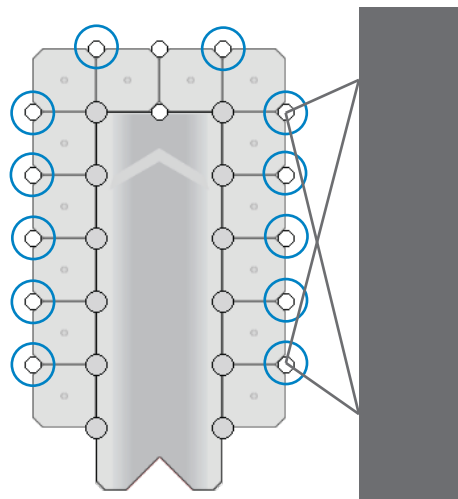
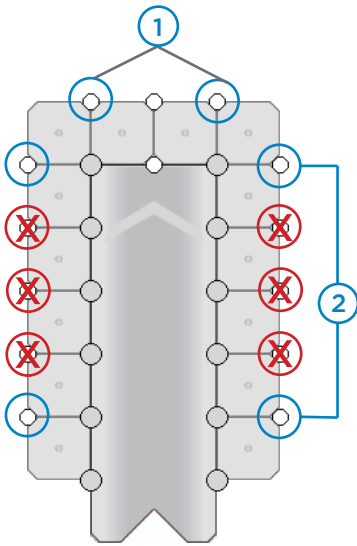

NOTES:

NOTES:

- To be installed on a fixed dock or structure. The 1 11/16” pile must also be driven into the sea bed.
- Minimum of 2 BRACKETS
- The piles are directly inserted through the dock leg support, then the cube tabs and then into the sea bed.
- Always keep the anchoring symmetrical left/right.
- These guidelines are imperative to insure full warranty coverage
- In doubt, please refer to your Candock representative.
- *Do not use if water level can go over the fixed structure, at any given moment.

- Minimum of 2 FASTENING POINTS
- If placed on the side of the system, make sure the “rear” ropes will allow vertical movement when PWC is going up and down the JETSLIDE
- In doubt, please refer to your Candock representative.

CONFIGURATIONS AND ANCHORING GUIDELINES FOR “BOAT” JETSLIDE SYSTEMS

1-THE CHART

These are the most common configurations for JETSLIDE assembly for boats under 6000lbs. Note that these will cover most of the possible situations but some exceptions may apply even if you abide to all of the following rules. Indeed, since January 2013, we are requesting that every JETSLIDE configuration gets approved prior to its installation. The following guidelines are mandatory for optimal ease of use and for warranty coverage policies. Please act accordingly.

BOAT LENGTH		BOAT WEIGHT		JETSLIDE	CUBE ROWS	SAFETY PLATE			V-PLATE	AIR ASSIST	STIFFENING BEAMS
METRIC (M)	IMPERIAL (FT)	METRIC	IMPERIAL			SIDES AND FRONT	1 CUBE	2 CUBES			
0 - 3,5	0 - 11,5	< 565 kg	< 1250 lbs	1	1	-	-	-	-	-	-
3,5 - 4	11,5 - 13	< 565 kg	< 1250 lbs	1	1	1	-	-	-	-	-
3,5 - 4	11,5 - 13	< 1360 kg	< 3000 lbs	1	2	1	-	-	-	-	-
4 - 4,5	13 - 14,5	< 565 kg	< 1250 lbs	1	1	-	1	-	-	-	-
4 - 4,5	13 - 14,5	< 1360 kg	< 3000 lbs	1	2	-	1	-	-	-	-
4,5 - 5	14,5 - 16,5	< 565 kg	< 1250 lbs	1	1	-	-	1	-	-	-
4,5 - 5	14,5 - 16,5	565 - 910 kg	1250 - 2000 lbs	1	1	-	-	1	-	-	-
4,5 - 5	14,5 - 16,5	910 - 1360 kg	2000 - 3000 lbs	1	2	-	-	1	-	-	3
4,5 - 5	14,5 - 16,5	1360 - 1820 kg	3000 - 4000 lbs	1	2	-	-	1	-	1	2
4,5 - 5	14,5 - 16,5	1820 - 2270 kg	4000 - 5000 lbs	1	2	-	-	1	-	1	2
4,5 - 5	14,5 - 16,5	2270 - 2730 kg	5000 - 6000 lbs	1	2	-	-	1	-	1	3
5 - 6,5	16,5 - 21	910 - 1360 kg	2000 - 3000 lbs	2	2	-	-	-	1	-	3
5 - 6,5	16,5 - 21	1360 - 1820 kg	3000 - 4000 lbs	2	2	-	-	-	1	1	2
5 - 6,5	16,5 - 21	1820 - 2270 kg	4000 - 5000 lbs	2	2	-	-	-	1	1	2
5 - 6,5	16,5 - 21	2270 - 2730 kg	5000 - 6000 lbs	2	2	-	-	-	1	1	3
6,5 - 7	21 - 22,5	910 - 1360 kg	2000 - 3000 lbs	2	2	1	-	-	1	-	3
6,5 - 7	21 - 22,5	1360 - 1820 kg	3000 - 4000 lbs	2	2	1	-	-	1	1	2
6,5 - 7	21 - 22,5	1820 - 2270 kg	4000 - 5000 lbs	2	2	1	-	-	1	1	2
6,5 - 7	21 - 22,5	2270 - 2730 kg	5000 - 6000 lbs	2	2	1	-	-	1	1	3
7 - 7,5	22,5 - 24	910 - 1360 kg	2000 - 3000 lbs	2	2	-	1	-	1	-	3
7 - 7,5	22,5 - 24	1360 - 1820 kg	3000 - 4000 lbs	2	2	-	1	-	1	1	2
7 - 7,5	22,5 - 24	1820 - 2270 kg	4000 - 5000 lbs	2	2	-	1	-	1	1	2
7 - 7,5	22,5 - 24	2270 - 2730 kg	5000 - 6000 lbs	2	2	-	1	-	1	1	3
7,5 - 8	24 - 25,5	910 - 1360 kg	2000 - 3000 lbs	2	2	-	-	1	1	-	3
7,5 - 8	24 - 25,5	1360 - 1820 kg	3000 - 4000 lbs	2	2	-	-	1	1	1	2
7,5 - 8	24 - 25,5	1820 - 2270 kg	4000 - 5000 lbs	2	2	-	-	1	1	1	2
7,5 - 8	24 - 25,5	2270 - 2730 kg	5000 - 6000 lbs	2	2	-	-	1	1	1	3
8 - 9	25,5 - 30	910 - 1360 kg	2000 - 3000 lbs	3	2	-	-	-	2	-	3
8 - 9	25,5 - 30	1360 - 1820 kg	3000 - 4000 lbs	3	2	-	-	-	2	1	2
8 - 9	25,5 - 30	1820 - 2270 kg	4000 - 5000 lbs	3	2	-	-	-	2	1	2
8 - 9	25,5 - 30	2270 - 2730 kg	5000 - 6000 lbs	3	2	-	-	-	2	1	3

CONFIGURATIONS AND ANCHORING GUIDELINES FOR “BOAT” JETSLIDE SYSTEMS

2-THE 4 POSSIBLE ANCHORING OPTIONS

2.1 - PILINGS

IDEAL ASSEMBLY

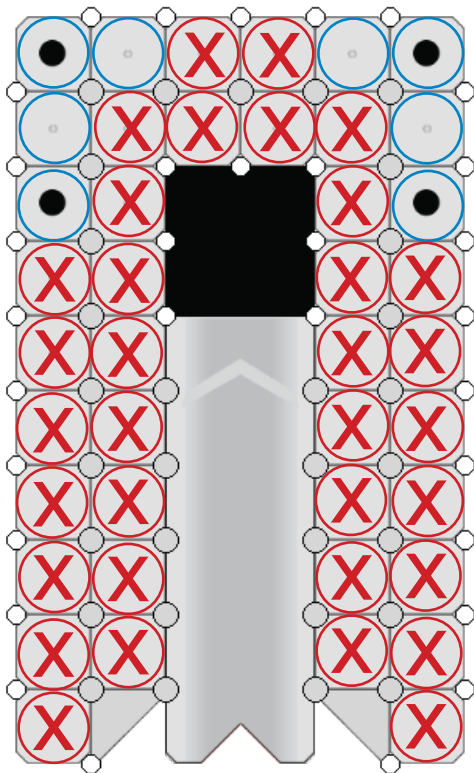

RULES:

- Minimum of 4 PILES should be considered at all time
- Max. water depth is 2m / 6'.
- If Using only PILINGS as anchoring technique, the size of the whole configuration is limited to 1 JETSLIDE along with 1 SAFETY PLATE 3 CUBES. If assembly requires a second JETSLIDE, a combination of multiple anchoring techniques will have to be adopted.
- Always keep the anchoring symmetrical left/right.
- As a safety or simply to optimize the efficiency and sturdiness of your system, regular ropes tied to cleats may also be added at the rear of the system
- Always leave a minimum of 1 regular cube between each G2 POST CUBE
- These guidelines are imperative to insure full warranty coverage
- In doubt, please refer to your Candock representative.

CONFIGURATIONS AND ANCHORING GUIDELINES FOR “BOAT” JETSLIDE SYSTEMS

2.2 - ANCHORING STRUTS

IDEAL ASSEMBLY

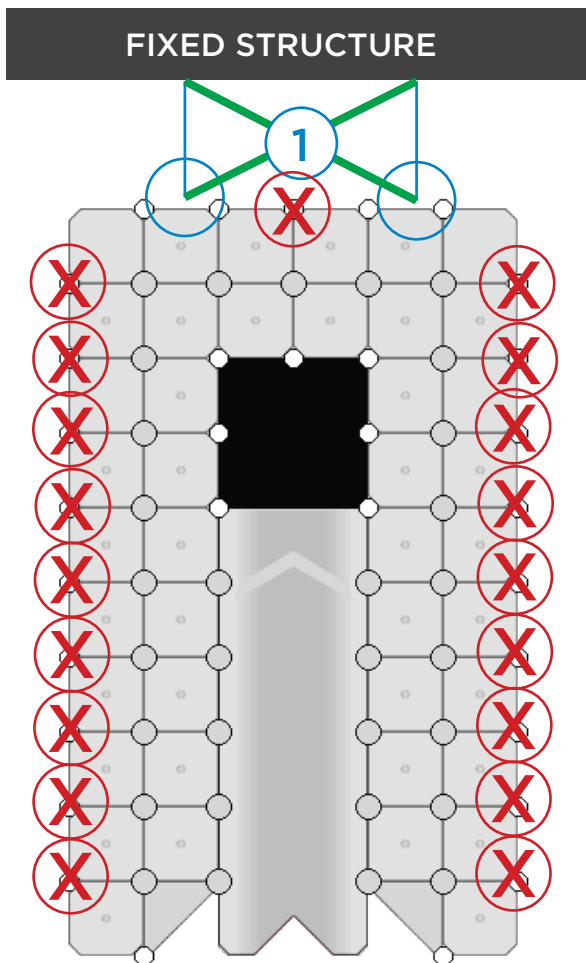

RULES:

-A Minimum of 2 ANCHORING STRUTS should be considered at all time

-make sure to include the required steel cable in “X” position between struts.

-If Using only ANCHORING STRUTS as anchoring technique, the size of the whole configuration is limited to 1 JETSLIDE along with 1 SAFETY PLATE 3 CUBES. If the system requires a second JETSLIDE, a combination of multiple anchoring techniques will have to be adopted.

-Always keep the anchoring symmetrical left/right.

-As a safety or simply to optimize the efficiency and sturdiness of your system, regular ropes tied to cleats may also be added at the rear of the system

-These guidelines are imperative to insure full warranty coverage

-In doubt, please refer to your Candock representative.

CONFIGURATIONS AND ANCHORING GUIDELINES FOR “BOAT” JETSLIDE SYSTEMS

2.3 - WALL ANCHORAGE

IDEAL ASSEMBLY

FLOATING STRUCTURE

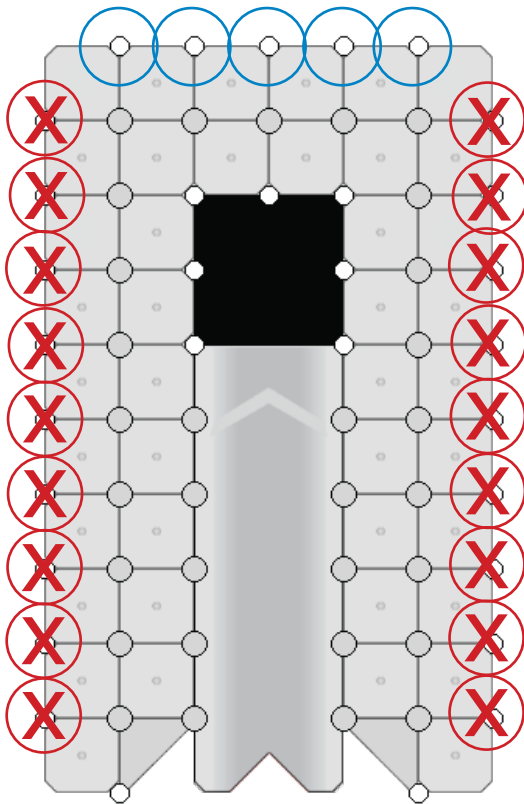

RULES:

-A Minimum of **3 WALL ANCRAGES** should be considered at all time

-If Using only **WALL ANCRAGES** as anchoring technique, **the size of the whole configuration is limited to 1 JETSLIDE along with 1 SAFETY PLATE 3 CUBES.** If the system requires a second **JETSLIDE**, a **combination of multiple anchoring techniques** will have to be adopted.

-As a safety or simply to optimize the efficiency and sturdiness of your system, regular ropes tied to cleats may also be added at the rear of the system

-Always keep the anchoring symmetrical **left/right.**

-These guidelines are imperative to insure full warranty coverage

-In doubt, please refer to your Candock representative.

CONFIGURATIONS AND ANCHORING GUIDELINES FOR “BOAT” JETSLIDE SYSTEMS

2.4 - COMBINATIONS INCLUDING UNDER WATER ANCHORING POINTS

IDEAL ASSEMBLY

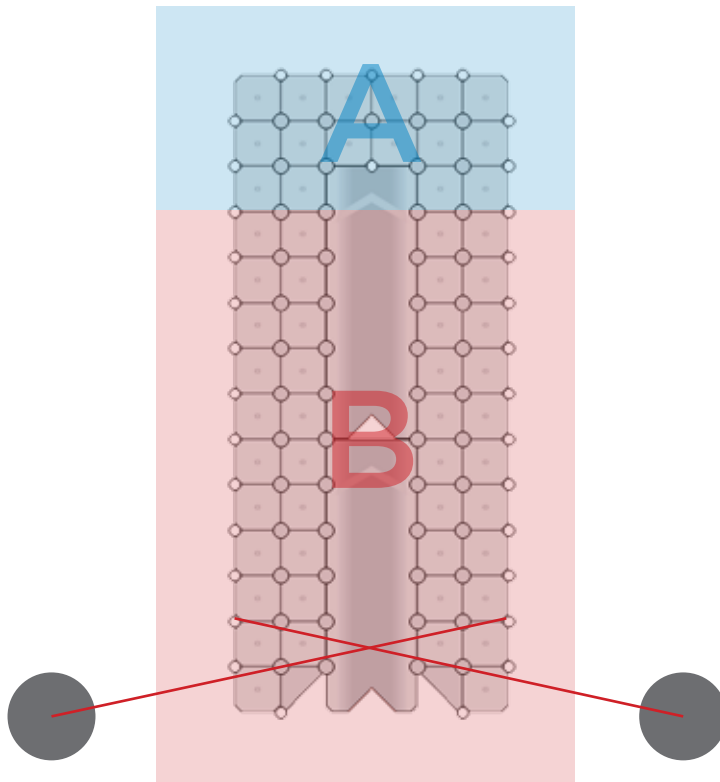

RULES:

- Make sure to abide to all pre-mentioned rules and guidelines.
- If boat is longer than 16.5 ft, a combination of anchoring products is required.
- If boat is heavier than 2000 lbs, a combination of anchoring products is required.
- The heavier the baot is, the stronger/heavier the REAR anchor points need to be.
- Anchoring items featured in zone **A** should always consist of either **PILINGS, ANCHORING STRUTS** or **WALL ANCHORAGES**.
- Anchoring items featured in zone **B** should always consist of either **UNDER WATER ANCHORING POINTS** or **ROPES AND CLEATS**.
- If placed on the side of the system, make sure the “rear” ropes will allow vertical movement when BOAT is going up and down the **JETSLIDE**
- A Minimum of 4 **ANCHOR POINTS** should be considered at all time.
- Always keep the anchoring symmetrical **left/right**.

-If using **UNDER WATER ANCHOR POINTS**, simply ask your dealer for recommended weight/type of anchors and special attachments. You will have to use galvanized or stainless steel 5/16”chain or good quality marine rope. The length will depend on water depth and variations of the water level. When using this type of anchoring, it is normal that the JetSlide moves slightly forward when entering the unit and backwards when exiting the unit. **This is why you need to check regularly the tightness of the chains to limit this movement.**

-These guidelines are imperative to insure full warranty coverage

-In doubt, please refer to your Candock representative.

CONFIGURATIONS AND ANCHORING GUIDELINES FOR “BOAT” JETSLIDE SYSTEMS

IMPORTANT NOTIONS

1-The **JETSLIDE SYSTEM FOR BOATS** can simply be attached to an existing dock using **WALL ANCHORAGES*** (* If fixed to **FLOATING STRUCTURE ONLY**), **ANCHORING STRUTS** or a custom-made bracket that will be approved beforehand by an authorized Candock representative. Regular ropes and cleats may be also consist of anchoring/fixing accessories but we suggest that the watercraft using the systeme is under 1500 lbs.If you tie the **JETSLIDE SYSTEM FOR BOATS** to an existing dock, make sure that the dock is sturdy enough to resist the forward and backward movement generated by the watercraft when it enters or goes down the system.

2-The **JETSLIDE SYSTEM FOR BOATS** can also be added to an existing Candock system. Make sure that the dock is anchored well enough to resist the forward and backward movement generated by the watercraft when it enters or goes down the JetSlide.